

# **ICF-1180I Series Quick Installation Guide**

---

**Version 8.2, January 2021**

**Technical Support Contact Information**  
**[www.moxa.com/support](http://www.moxa.com/support)**

**MOXA<sup>®</sup>**

© 2021 Moxa Inc. All rights reserved.

**P/N: 1802011800030**



## Introduction

There are two variations of PROFIBUS protocol, PROFIBUS DP (Decentralized Peripherals) and PROFIBUS PA (Process Automation). PROFIBUS PA is used with applications for which the end device needs a power supply from the PROFIBUS PA device and where an intrinsic safe mechanism is also required. Due to the power supply criteria, the number of attached devices is limited. PROFIBUS DP is used in production automation and when centralized controllers are used to manage the system. It supports up to 126 attached devices and is the most commonly used PROFIBUS specification.

The ICF-1180I series PROFIBUS-to-fiber converters are based on PROFIBUS DP. ICF-1180I products are used to convert PROFIBUS signals from copper to optical fiber. ICF-1180I multi-mode models can be used to extend PROFIBUS signal transmission up to 4 km and ICF-1180I single-mode models can extend PROFIBUS signal transmission up to 45 km. ICF-1180I converters provide 2 kV isolation protection for the PROFIBUS system and have dual power inputs to ensure uninterrupted operation of the PROFIBUS device.

## Why Convert PROFIBUS to Fiber?

Optical fiber communication not only extends the communication distance, but also provides many advantageous features.

**IMMUNITY FROM ELECTRICAL INTERFERENCE:** Fiber is immune from electromagnetic interference or radio frequency interference. It provides a clean communication path and is immune to cross-talk.

**INSULATION:** Optical fiber is an insulator interface; the glass fiber eliminates the need for using electric currents as the communication medium.

**SECURITY:** Fiber cannot be tapped by conventional electronic means and is very difficult to tap into optically while radio and satellite communication signals can be captured easily for decoding.

**RELIABILITY & MAINTENANCE:** Fiber is immune from adverse temperature and moisture conditions; hence, it does not corrode or lose its signal, and is not affected by short circuits, power surges, or static electricity.

## Auto/Manual Baudrate Settings

The ICF-1180I series converts signals back and forth between PROFIBUS and fiber and supports baudrates from 9.6 kbps to 12 Mbps. Engineers do not need to know the baudrate of the connected PROFIBUS device since the ICF-1180I can automatically detect the baudrate of the PROFIBUS device and apply this baudrate directly. This is an extremely convenient feature. If necessary, baudrates can be set to a fixed value via DIP switches.

## PROFIBUS Fail Safe

When the PROFIBUS device malfunctions or the serial interface fails, it will generate electrical noise that can cause bus failure. Traditional media converters will let the noise signal pass through the fiber and on to the other converter, disrupting data communication between the two buses and eventually causing communication to cease across the entire system. When this occurs, engineers will not be able to easily locate the failed device because the entire PROFIBUS network is down. To avoid this situation, the ICF-1180I is designed to detect and recognize noise signals. If the bus fails on one side, the noise signal will not propagate through the ICF-1180I and affect additional bus segments. In addition, the ICF-1180I will also trigger an alarm notification to the field engineer on the location of the failure.

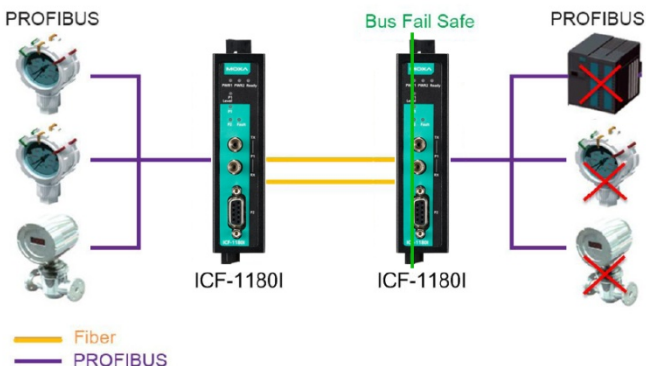

## Fiber Link Monitor

The ICF-1180I series' Fiber Link Monitor function detects communication errors on either the fiber side or the PROFIBUS side. When a communication error occurs, the corresponding LED will shine red and the relay alarm will activate.

## Reverse Power Protection

The Reverse Power Protection feature provides extra protection against accidentally connecting the power cables to the wrong terminal. The converter is designed to detect automatically which power wire is positive and which is negative, and then adjust the power supply accordingly.

## Remote Fiber Diagnosis

Fiber optic cables are often deployed for long distance communication and a fiber optic inspection pen is used by engineers to detect communication quality issues. ICF-1180I series converters eliminate the need for a fiber optic inspection pen by providing a Fiber Test function that uses DIP switch adjustments. By using the Fiber Test function, users can determine which side (Tx or Rx) is causing the problem on the converter. Fiber cable abnormalities can be automatically detected and identified by the LED indicator.

### **Using Remote Fiber Diagnosis:**

Set DIP switch SW8 to the ON position on any ICF-1180I converter and then look at the Ready LED status. A flashing green Ready LED indicates that the Fiber Test has finished. The P1 (Fiber port) LED indicates which side (Tx or Rx) is causing the problem. If there are no fiber connection errors in the entire topology, the related LEDs will shine green or remain OFF. If the fiber connection error is adjacent to the converter, the status will also be indicated by the P1 LEDs. A flashing red light on P1 means that the Rx fiber cable connected to this port is broken. Similarly, a solid red light on P1 means that the Tx fiber cable in this port is broken. Further descriptions and troubleshooting can be found in the Troubleshooting table.

## **Features**

- Auto baudrate detection and data speed up to 12 Mbps
- PROFIBUS bus fail safe
- Alarm by relay output
- 2 kV galvanic isolation
- Power polarity protection
- Extends PROFIBUS transmission distance:
  - Up to 45 km with single-mode—ICF-1180I-S series
  - Up to 4 km with multi-mode—ICF-1180I-M series
- Remote Fiber Diagnosis
- Topology: Point-to-Point mode, Linear mode (as the head or tail converter with ICF-1280I)
- Dual power inputs for redundancy
- Wide operating temperature range: -40 to 75°C (for “T” models)
- Supports Fiber Signal Intensity Diagnosis

## **Package Checklist**

Before installing the ICF-1180I converter, verify that the package contains the following items:

- ICF-1180I PROFIBUS-to-fiber converter
- Quick installation guide (printed)
- Warranty card

*Note: Please notify your sales representative if any of the above items are missing or damaged.*

# Mounting Dimensions (unit: mm)

Top View

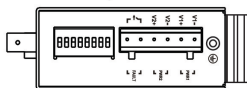

Side View

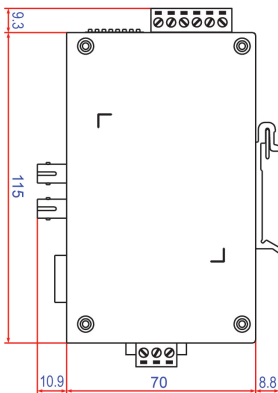

Rear View

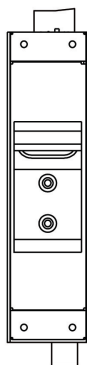

Bottom View

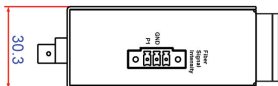

Front View

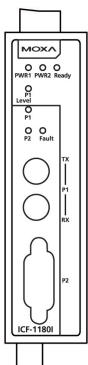

# ICF-1180I Panel Layouts

## Top View

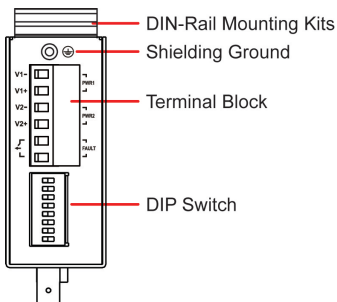

## Bottom View

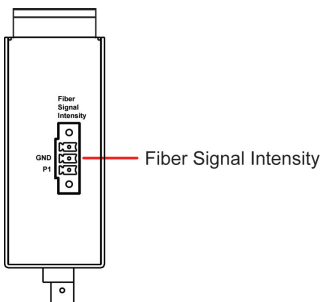

## Front View

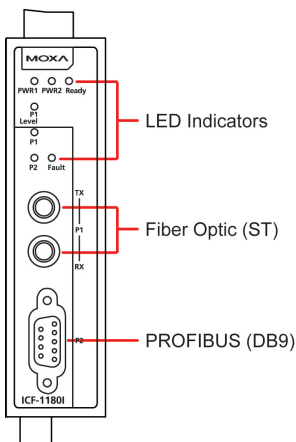

## ATTENTION

### Electrostatic Discharge Warning!

To protect the product from damage due to electrostatic discharge, we recommend wearing a grounding device when handling your ICF-1180I.

## Mounting

The aluminum DIN rail attachment plate should be fixed to the back panel of the ICF-1180I when you take it out of the box. If you need to reattach the DIN rail attachment plate to the ICF-1180I, make sure the stiff metal spring is situated towards the top, as shown in the figures below.

### STEP 1:

Insert the top of the DIN rail into the slot just below the stiff metal spring.

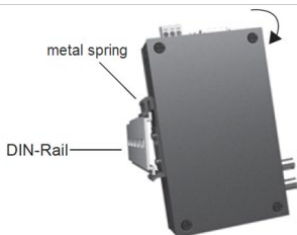

### STEP 2:

The DIN-rail attachment unit will snap into place as shown below.

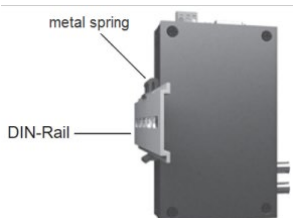

To remove the ICF-1180I series from the DIN rail, simply reverse Steps 1 and 2 above.

## Wiring the Alarm Contact

The alarm contact is made up of the two middle contacts of the terminal block on the ICF-1180I's top panel. Refer to the next section for detailed instructions on how to connect the wires to the terminal block connector, and how to attach the terminal block connector to the terminal block receptor.

In this section, we explain the meaning of the two contacts used to connect the alarm contact.

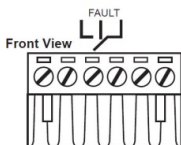
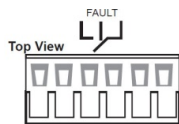

**FAULT:** The two middle contacts of the 6-contact terminal block connector are used to detect both power faults and port faults. The two wires attached to the Fault contacts form an open circuit when:

1. The ICF-1180I has lost power from one of the DC power inputs.
- OR
2. One of the ports for which the corresponding PORT ALARM Dip Switch is set to ON is not properly connected.

If neither of these two conditions occurs, the Fault circuit will be closed.

## Wiring the Redundant Power Inputs

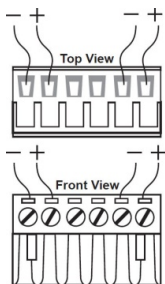

**STEP 1:** Insert the negative/positive DC wires into the V-/V+ terminals.

**STEP 2:** To keep the DC wires from pulling loose, use a small flat-blade screwdriver to tighten the wire-clamp screws on the front of the terminal block connector.

**STEP 3:** Insert the plastic terminal block connector prongs into the terminal block receptor, which is located on the ICF-1280I's top panel.



### ATTENTION

Before connecting the ICF-1180I to the DC power inputs, make sure the DC power source voltage is stable.

You should also pay attention to the following:

- The temperature rating of the input connection cable should be higher than 91°C.
- The cross sectional area of the ground wire should be at least 3.31 mm<sup>2</sup>.
- The terminal block plug should be suitable for 28-12 AWG (0.0804-3.31 mm<sup>2</sup>) wire and a torque of 4.5 lb-in.

## Fiber Cable

### ST-Port Pinouts



### ST-Port to ST-Port Cable Wiring



### Cable Wiring

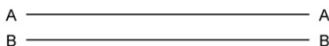

## Pin Assignment

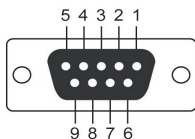

PIN	Signal Name
1	N.C.
2	N.C.
3	PROFIBUS D+
4	RTS
5	Signal common
6	5 V
7	N.C.
8	PROFIBUS D-
9	N.C.



## Federal Communications Commission Statement

FCC: This device complies with part 15 of the FCC Rules. Operation is subject to the following two conditions:

1. This device may not cause harmful interference, and
2. This device must accept any interference received, including interference that may cause undesired operation.

## ATEX and IECEx Information

1. Certificate number  
ATEX: DEMKO 14 ATEX 1384X  
IECEX: IECEX UL 14.0094X
2. Ambient range  
-40°C ≤ Tamb ≤ 75°C for models with suffix of "-T"  
-10°C ≤ Tamb ≤ 60°C for models without suffix of "-T"
3. Certification string:  
ATEX: Ex nA nC op is IIC T4 Gc  
IECEX: Ex nA nC IIC T4 Gc
4. Standards covered:  
EN 60079-0:2012+A11:2013/IEC 60079-0:2011 Ed.6  
EN 60079-15:2010/IEC 60079-15:2010 Ed.4; EN 60079-28:2015
5. Conditions of safe usage:
  - This equipment must be installed in an enclosure that can only be accessed with a key or other tool, and which provides a degree of protection not less than IP54 in accordance with IEC 60079-15.
  - These devices are designed for use in an area of not more than pollution degree 2 in accordance with EN/IEC 60664-1.
  - Transient protection must be provided and set at a level not exceeding 140% of the peak rated voltage value at the supply terminals to the equipment.



## Slot Time Settings

When ICF-1180I converters are used as part of a PROFIBUS network, frame delays can occur, with the time of the delays determined by the total cable length and network topology. In this case, a sufficient "slot time" should be configured to prevent the PROFIBUS master from timing out. We recommend using the following formula to calculate the preferred PROFIBUS master's slot time.

For a point-to-point topology:

$$\text{Slot time} = A + B \times L + 13 \times N$$

Transmission Speed (kbps)	A	B
12000	811	120
6000	461	60
3000	261	30
1500	161	15
500	111	5
187.5	71	1.875
93.75	71	0.9375
45.45	411	0.4545
19.2	71	0.192
9.6	71	0.096

**L:** The length of the fiber optic cable in kilometers.

**N:** The number of converters in the system.

**A and B:** Parameters determined by the transmission speed.

Note: To avoid frame conflicts, we recommend setting the PROFIBUS command retry limit  $\geq 3$ , and the slot time  $< 262128$ .

## DIP Switch Settings

There are 8 DIP switches on the top panel of the ICF-1180I. The factory default setting for all DIP switches, except SW5, is **OFF**.

Transmission Speed (kbps)	SW1	SW2	SW3	SW4
Auto (default)	OFF	OFF	OFF	OFF
12000	OFF	OFF	OFF	ON
6000	OFF	OFF	ON	OFF
3000	OFF	OFF	ON	ON
1500	OFF	ON	OFF	OFF
500	OFF	ON	OFF	ON
187.5	OFF	ON	ON	OFF
93.75	OFF	ON	ON	ON
45.45	ON	OFF	OFF	OFF
19.2	ON	OFF	OFF	ON
9.6	ON	OFF	ON	OFF

Setting	ON	OFF
SW5	Fiber Link Monitor	Disable
SW6	Reserved	Reserved
SW7	Reserved	Reserved
SW8	Remote Fiber Diagnosis*	Disable

\* Refer to the Remote Fiber Diagnosis section for instructions.



### ATTENTION

If you connect an ICF-1180I converter running firmware version 1.2 to (a) an ICF-1180I converter running firmware version 1.3 or above, or (b) an ICF-1280I converter, the built-in **Fiber Link Monitor** and **Fiber Test** functions may not work properly. Users must disable the **Fiber Link Monitor** function through the DIP switch and the **Fiber Test** function will work in this situation. Version 1.3 of the ICF-1180I converter is fully compatible with the ICF-1280I series for the **Fiber Link Monitor** function and the **Remote Fiber Diagnosis** function.

Version 1.4 of ICF-1180I converter change the function name "Fiber Test" to "Remote Fiber Diagnosis"

## LED Indicators

There are 7 LEDs on the front panel of the ICF-1180I.

LED	Color	Description	Relay Status
PWR1/ PWR2	Solid green	Power is on	Closed
	Off	Power is off, or power error condition exists	Open
Ready	Solid green	Baudrate is detected, converter is ready for communication	Closed
	Flashing green*	Fiber diagnosis is finished	Closed
	Flashing red*	Detecting baudrate	Closed
	Flashing red and green*	Slotting time setting error	Closed
	Off	System power is off	Closed
Fault	Solid green	Fiber connections are working normally in Fiber Diagnosis mode	Closed
	Flashing red*	Fiber abnormality has occurred in another segment	Closed
	Solid red*	Fiber abnormality has occurred in this converter	Closed
P1 Level	Green	Fiber Component Strength Normal	Closed
	Orange	Fiber Component Strength is in the critical level, it might abnormal soon.	Closed
	Red	Fiber Component strength is fail or Fiber cable too long	Open
P1 (Fiber)	Flashing/ solid green	Fiber port is receiving data	Closed
	Solid red*	Fiber cable linking to Tx is abnormal	Open
	Flashing red*	Fiber cable linking to Rx is abnormal	Open
	Off	Fiber in idle state	Closed
P2 (PROFIBUS)	Flashing green	PROFIBUS port is communicating	Closed
	Flashing red	Inner transceiver IC defective; PROFIBUS port data communication error; insufficient shielding of the bus cable; echo package timeout	Open
	Solid red	Echo package timeout, PROFIBUS UART character error	Open
	Off	PROFIBUS in idle state	Closed

If both power inputs experience an outage, the relay will become an open circuit for alarm purposes.

\* Refer to the following table for troubleshooting information.

## Troubleshooting LED Indicators and Fiber Test

LED	Color	Description	Status/Troubleshooting
Ready	Flashing green	Fiber diagnosis finished	At least one converter is in Fiber Diagnosis mode; Check PROFIBUS master settings; Tx and Rx cables crossed
	Flashing red	Detecting baudrate	No PROFIBUS node; No PROFIBUS signal received; Tx and RX crossed over; Baudrate setting is incorrect.
	Flashing green/red	Slot time setting error	Recalculate the slot time; Set TSDR $\geq 11$ ; Set HAS = greatest PROFIBUS node address + 1; Check consistency of operation mode for DIP switch 6/7; Check consistency of Fiber Link Monitor Mode for DIP switch 5
P1	Flashing red	Rx fiber cable abnormality	Check the Rx fiber cable connecting to this port*; Tx and Rx cables crossed over; Partner module is powered OFF or defective
	Solid red	Tx fiber cable abnormality	Check the fiber cable linking to Tx of this port*
P2	OFF	PROFIBUS is idle	Check the PROFIBUS device connection
	Flashing red	PROFIBUS side error	RS-485 cable is not terminated or only terminated at one end; Open bus cable; PROFIBUS D+ and D- crossed over; Short circuit on PROFIBUS cable; RS-485 driver is defective; Check slot time setting, baudrate, and operation mode

If the abnormality indicated by the LED disappears in Fiber Diagnosis mode, check the consistency of the DIP switch settings on all the converters.

If the Tx and Rx cables are both abnormal, the P1 LED will shine red. Check the Rx cable first for troubleshooting.

\*If the P1 LED and P2 LED are both lit/flashing red simultaneously, the Tx and Rx cables of P1 and P2 may be crossed.



### ATTENTION

This is a Class 1 laser/LED product. Do not stare into the laser beam.

## Fiber Signal Intensity Diagnosis

In some circumstances you may need to measure the receive level of fiber optic channels P1 and P2 with a voltmeter, which can be connected while the device is operating (doing so will not affect data transmission). The measurement can be taken with a voltmeter and read on a PLC that uses floating high impedance analog inputs, which allows you to do the following:

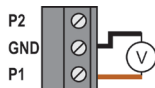

- The incoming optical power to be recorded for later measurement (e.g., to indicate aging or damage).
- You can carry out a good/bad test (limit value).

You must use a high-resistance, ungrounded voltmeter to conduct the measurements, but whatever you do, don't connect the ground connector to the housing, since doing so could affect data transmission. In addition, the measuring cables must be less than 3 meters in length to meet EMC requirements. Refer to the diagrams below to estimate the quality of the bus traffic based on the receiving levels.

**NOTE** For a valid measurement, the partner ICF-1180I at the other end of the fiber-optic cable must send normal PROFIBUS frames. This can be recognized by the LED display of the partner ICF.

A number of different factors can affect the output voltages at the measurement sockets:

- The partner ICF-1180I's optical transmit power
- The optical transmitter and receiver's ambient temperature
- The transmission line attenuation
- The transmission rate that's in use

Keep in mind that these measurement sockets are not meant to replace a proper calibrated level measuring device that has a calibrated light source. The values obtained from the measurement sockets can only be used to classify the received optical signals into one of 4 categories:

- Good (normal operation, green),  $3\text{ V} > U > 480\text{ mV}$
- Critical (optical link margin reduced, yellow),  $330\text{ mV} \leq U \leq 480\text{ mV}$
- Bad (functionality not guaranteed, red),  $U < 330\text{ mV}$
- Fiber cable unplugged,  $U < 160\text{ mV}$

When taking measurements, use a standard ungrounded, high-resistance voltmeter. The internal resistance of the measurement sockets is approximately 30 kΩ. Keep in mind that you must not connect the measurement sockets or reference potential to the ICF housing.

- **Multi-mode: ICF-1180I-M-ST**

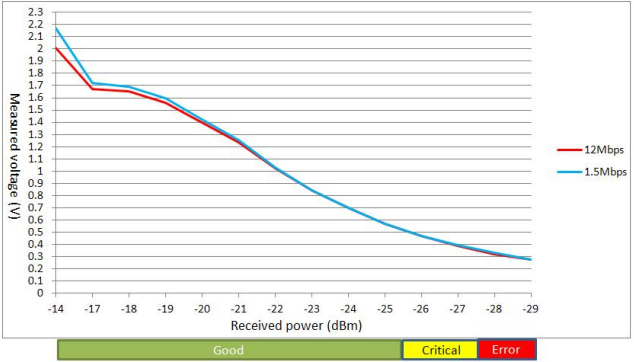

- **Single-mode: ICF-1180I-S-ST**



**NOTE** These charts are not suitable for use with a Remote Fiber Diagnosis test.

## Specifications

<b>PROFIBUS Communication</b>	
PROFIBUS Interface	PROFIBUS DP
Number of Ports	1
Connector	DB9 female
Isolation Protection	2 kV
Baudrate	9.6 Kbps to 12 Mbps
Auto Baudrate	Yes
<b>Fiber Communication</b>	
Connector type	ST
Distance	Single-mode fiber for 45 km Multi-mode fiber for 4 km
Support Cable:	Single mode: 8.3/125, 8.7/125, 9/125 or 10/125 $\mu\text{m}$ Multi-mode: 50/125, 62.5/125, or 100/140 $\mu\text{m}$
Wavelength	ICF-1180I-S: 1310 nm ICF-1180I-M: 820 nm
Tx Output	ICF-1180I-S: -7 dBm ICF-1180I-M: -14 dBm
Rx overload	ICF-1180I-S: -3 dBm ICF-1180I-M: -3 dBm
Rx Sensitivity	ICF-1180I-S: -29 dBm ICF-1180I-M: -28 dBm
Point-to-Point Transmission	Half duplex
<b>Environmental</b>	
Operating Temperature	0 to 60°C (32 to 140°F) -40 to 75°C (-40 to 167°F), for -T models
Storage Temperature	-40 to 75°C (-40 to 167°F), for -T models
Ambient Relative Humidity	5 to 95% (non-condensing)
Atmospheric pressure	Up to 2000 m (795 hPa), higher altitudes available on demand
<b>Power</b>	
Input Power Voltage	12 to 48 VDC
Connector	Terminal block
Power Line Protection	IEC 6000-4-5 Level 3 (2 kV) Surge Protection
Power Polarity Protection	Protects against V+/V- reversal
Over Current Protection	1.1 A
Power Consumption	269 mA max. (single mode: 143 mA @ 24 VDC, multi-mode: 130 mA @ 24 VDC)
Relay Output	1 digital output relay to alarm (Normal: closed) Current carrying capacity: 2 A @ 30 VDC
<b>Mechanical</b>	
Dimensions	30.3 × 70 × 115 mm
Material	Aluminum (1 mm)
Gross Weight	180 g

<b>Regulatory Approvals</b>	
Safety	UL 508
Hazardous Location	UL/cUL Class I, Division 2, Groups A, B, C, and D DNV.2.4 (not suitable for installation on a bridge) ATEX Zone 2: Ex nA nC op is IIC T4 Gc IEC 60079-0:2011 Ed.6 IEC 60079-15:2010 Ed.4; EN 60079-28:2015
EMC	CE; FCC Part 15, sub part B, Class A
EMI	EN 55032, Class A; EN 55024
EMS	EN 61000-4-2 (ESD), Level 3, Criteria A EN 61000-4-3 (RS), Level 3, Criteria A EN 61000-4-4 (EFT), Level 3, Criteria B EN 61000-4-5 (Surge), Level 3, Criteria B EN 61000-4-6 (CS), Level 3, Criteria B
Freefall	IEC 60068-2-32
MTBF	792,085 hrs.