

# SCTP20



## Programmable 2-Wire Temperature Transmitter, Head Mount

### Description

Each SCTP20 2-wire transmitter is designed for measuring temperature using thermocouples or RTDs. The input type, measurement range, and other features are software configurable. A PC, the DSCX-887 and DSCX-440 interface cables, and the DSCX-895 configuration software are required to configure the transmitter. Communication is serial RS-232C. User can choose an isolated or non-isolated model.

The SCTP20 can interface to 12 industry standard thermocouple types: J,K,T,E,R,S,B,N,L,U,C, and D. Cold junction compensation is selectable as either internal or external. Three RTD types, Pt 100, Cu50\*, and Ni 100, can be interfaced in a two, three or four wire connection. All inputs are linearized using up to 23 points of interpolation, and total errors are less than  $\pm 0.2\%$ .

Other configurable features include: zero point and input range adjustment, output response for open or short-circuit sensor or cable failure, normal or inverted output, ripple suppression for 50Hz or 60Hz, and output time response. The DSCX-895 configuration software allows query, print-out and saving of configuration settings, display of input measurement value, and display of interpolation table points.

\*Call factory for Cu RTD information.

### ► Features

- No Power Supply Required, Powered From Output Loop Current
- Interfaces to All Standard Thermocouples and RTDs
- Software Configurable Input Type and Range
- Isolated (1500Vrms) and Non-Isolated Versions Available
- Open and Short-Circuit Input Detection
- Configurable with or without Output Loop Power Connected
- $-25^{\circ}\text{C}$  to  $+80^{\circ}\text{C}$  Operating Temperature
- CE Compliant

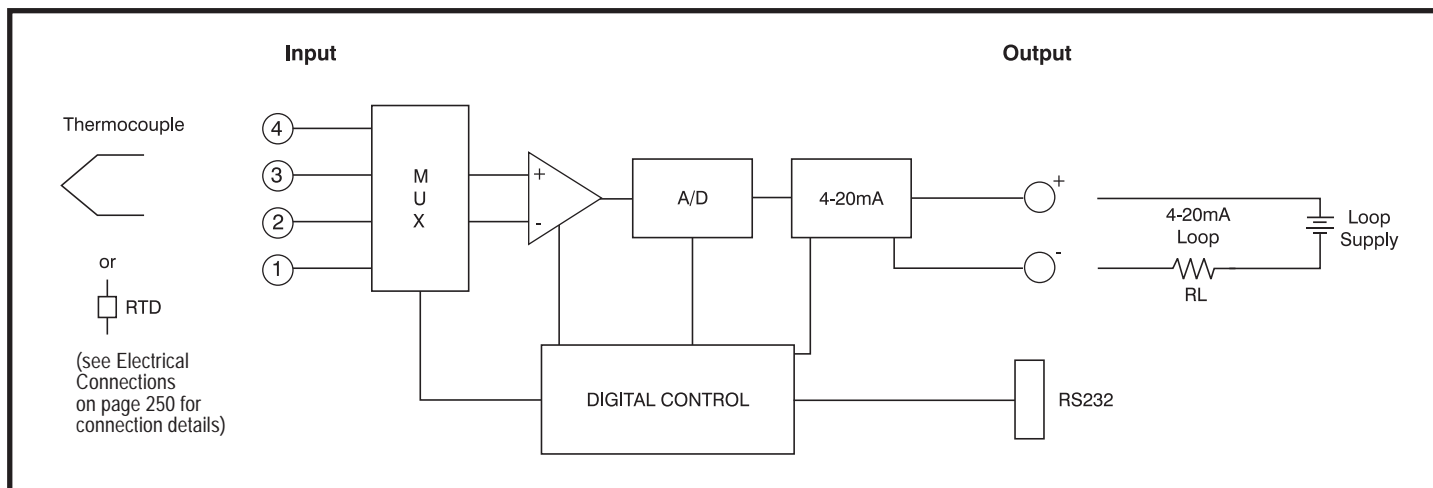

Figure 1: SCTP20 Block Diagram, Non-Isolated Model



The following grounding condition must be observed when programming the instrument.

If one of the power supply or input wires is grounded to earth, a PC without an earth connection must be used when programming (e.g. a Laptop running on batteries).

Under no circumstances should a PC be used running from a power supply with an earth connection, as this will damage the module.

### Thermocouple Type and Material

Type	Material
B	Pt30Rh-Pt6Rh
E	NiCr-CuNi
J	Fe-CuNi
K	NiCr-Ni
L	Fe-CuNi
N	NiCrSi-NiSi
R	Pt13Rh-Pt
S	Pt10Rh-Pt
T	Cu-CuNi
U	Cu-CuNi
C	W5 Re/W26 Re
D	W3 Re/W25 Re

**Specifications**

Typical at T<sub>a</sub>=+25°C, 24V loop supply voltage, R<sub>L</sub>=250Ω; PT100, 3 wire, 0-600°C

Module	SCTP20-01	SCTP20-02
Input Range, Thermocouple Thermocouple Types: B,E,J,K,N,R,S,T,L,U,C,D Cold Junction Compensation Internal External Input Resistance	Reference Table 1  Incorporated Pt 100 0 to 60°C, Configurable >10MΩ	*  * *
Input Range, RTD RTD Types: Pt 100, Ni 100 RTD Excitation Current Input Resistance Lead Resistance	Reference Table 1  ≤ 0.20mA >10MΩ ≤30Ω per Lead	*  * *
Output Range  CMV, Input to Output Output Noise Loop Supply Voltage Reverse Supply Protection Load Resistance Output Response for Input Failure Output Time Response	4 to 20mA or Inverse 20 to 4mA Not Isolated < 1% p-p 12 to 30 VDC Continuous See Note 1 Configurable to hold previous output value, or value between 4 and 21.6mA Configurable, see Table 2	*  1500Vrms, 1 min. * * * * *
Accuracy <sup>(2)</sup>	±0.1% Span Typ., ±0.2% Span max. <sup>1</sup>	*
Linearity	±0.03% Span Typ., ±0.1% Span max.	*
Stability	±(0.015%+0.015°C)/°C	*
Environmental Operating Temp. Range Storage Temp. Range Relative Humidity Emissions Immunity	-25°C to +80°C -40°C to +80°C 0 to 75% Noncondensing EN50081-2 (Radiated, Conducted) EN50082-2 (ESD, RF, EFT)	* * * * *
Mechanical Dimensions (h)(w)	0.66" x 1.69" (16.8mm x 43mm)	1.21" x 1.69" (30.8mm x 43mm)
Housing Material	Lexan 940, Flammability Class V0 According To UL 94	*
Mounting	Shape B Version Terminal Head	*

**NOTES:**

\* Same specification as SCTP20-01

(1) Load Resistance:  $R_L(max) = \frac{Loop\ Supply\ (V) - 12V}{I_{OUTPUT}(max)}$

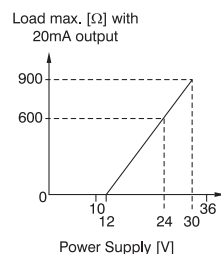

(2) Includes hysteresis, conformity and repeatability at reference conditions. Does not include CJC error.

(3) Shipped as PT 100 for 3-wire connection, 0 to 600°C range, 4 to 20mA output, open circuit detect = 21.6mA output.

(4) Submit configuration form shown on page 248, and factory will assign part number prior to order entry.

(5) Many different ranges may be programmed as long as the min/max limits are observed. For minimum range examples, a K type thermocouple could be programmed for +30°C to +78.5°C, or +100°C to +149°C, or +900°C to +995°C, and so on.

**Ordering Information**

Model	Input Range/Description	Output Range
SCTP20-01 (Basic Configuration) <sup>(3)</sup>	Factory User Configurable RTD or Thermocouple, Not Isolated	4 to 20mA, or Inverted
SCTP20-01-xxxx (Contact Factory) <sup>(4)</sup>	Factory User Configurable RTD or Thermocouple, Not Isolated	4 to 20mA, or Inverted
SCTP20-02 (Basic Configuration) <sup>(3)</sup>	Factory User Configurable RTD or Thermocouple, Isolated	4 to 20mA, or Inverted
SCTP20-02-xxxx (Contact Factory) <sup>(4)</sup>	Factory User Configurable RTD or Thermocouple, Isolated	4 to 20mA, or Inverted

**Accessories**

Model	Description
DSCX-887	PC Interface Cable
DSCX-440	Module Interface Cable
DSCX-895	Configuration Software

**Table 1**

Measured Variables	Measuring Ranges		
	Limits	Min. Span	Max. Span
RTD: 2, 3, or 4-wire Pt 100, Standard IEC 60 751 Ni 100, Standard DIN 43 760	-200 to +850°C -60 to +250°C	50°C 50°C	850°C 250°C
Thermocouple Type B, E, J, K, N, R, S, T; Standard IEC 60 584-1  Type L and U; Standard DIN 43 710  Type C: W5 Re/W26 Re, Type D: W3 Re/W25 Re; Standard ASTM E 988-90	According to type	2mV <sup>(5)</sup>	80mV <sup>(5)</sup>

**Table 2: Output Response Times**

Measuring Mode	Open Sensor Circuit	Short-Circuit	Possible Response Times [s]							
			1.5	2.5	3.5	6.5	11	20.5	40	
TC int. comp.	active	-	1.5	2.5	3.5	6.5	11	20.5	40	
TC int. comp.	off	-	1.5	2.5	3.5	6.5	13.5	24.5	49.5	
TC ext. comp.	active	-	1.5	2.5	3.5	6.5	11	20.5	40	
TC ext. comp.	off	-	1.5	2.5	4	6.5	13.5	24.5	48.5	
RTD 2L	active	-	2	2.5	3	5	9.5	17.5	33.5	
RTD 3L, 4L	active	active	2	2.5	4	6.5	11.5	21	40.5	
RTD 2L, 3L, 4L	off	off	1.5	2.5	3.5	7.5	14	26.5	50.5	

**†Additional Errors**

Low Measuring Range Resistance Thermometer (<200°C Span) Thermocouples (<500°C Span)		±0.015% Span Typ., ±0.05% Span max ±0.015% Span Typ., ±0.05% Span max
High Initial Value	Factor: Error:	±0.0002 Typ., ±0.0005 max (Factor)*(Initial Value/Span)*100 [%]
Influence of Lead Resistance		±0.01% per Ω
Internal Cold Junction Compensation		±(0.5°C/Span)*(100) [%]

SCTP

**Table 3: Temperature Measuring Ranges**

Measuring range examples [°C]	Resistance thermometers		Thermocouples											
	Pt100	Ni100	B	E	J	K	L	N	R	S	T	U	C <sup>(1)</sup>	D <sup>(2)</sup>
0...40	X			X	X		X							
0...50	X	X		X	X	X	X				X	X		
0...60	X	X		X	X	X	X				X	X		
0...80	X	X		X	X	X	X	X			X	X		
0...100	X	X		X	X	X	X	X			X	X		
0...120	X	X		X	X	X	X	X			X	X		
0...150	X	X		X	X	X	X	X			X	X	X	
0...200	X	X		X	X	X	X	X			X	X	X	X
0...250	X	X		X	X	X	X	X			X	X	X	X
0...300	X			X	X	X	X	X	X	X	X	X	X	X
0...400	X			X	X	X	X	X	X	X	X	X	X	X
0...500	X			X	X	X	X	X	X	X		X	X	X
0...600	X			X	X	X	X	X	X	X		X	X	X
0...800	X		X	X	X	X	X	X	X	X			X	X
0...900			X	X	X	X	X	X	X	X			X	X
0...1000			X	X	X	X		X	X	X			X	X
0...1200			X		X	X		X	X	X			X	X
0...1500			X						X	X			X	X
0...1600			X						X	X			X	X
0... 1800			X										X	X
0... 2000													X	X
50...150	X	X		X	X	X	X	X			X	X		
100...300	X			X	X	X	X	X			X	X	X	X
200...500	X			X	X	X	X	X	X	X		X	X	X
300...600	X			X	X	X	X	X	X	X		X	X	X
600...900			X	X	X	X	X	X	X	X			X	X
600...1000			X	X	X	X		X	X	X			X	X
900...1200			X		X	X		X	X	X			X	X
600...1600			X						X	X			X	X
600...1800			X										X	X
-10...40	X	X		X	X	X	X					X		
-30...60	X	X		X	X	X	X	X			X	X		
Measuring range limits [°C]	-200 to 850	-60 to 250	0 to 1820	-270 to 1000	-210 to 1200	-270 to 1372	-200 to 900	-270 to 1300	-50 to 1769	-50 to 1769	-270 to 400	-200 to 600	0 to 2315	0 to 2315
	<b>NOTE A</b>		<b>NOTE B</b>											
	<p><b>NOTE A:</b> Minimum span is 15Ω when the end value<sup>(3)</sup> is less than or equal to 400Ω.                      Minimum span is 150Ω when the end value<sup>(3)</sup> is greater than 400Ω and not exceeding 4000Ω.                      The ratio of the min value to the span must be less than or equal to 10.</p> <p><b>NOTE B:</b> Range of span is 2mV minimum to 80mV maximum. The ratio of the min value to the span must be less than or equal to 10.</p> <p><b>NOTE (1):</b> W5 Re W26 Re (ASTM E 988-90)</p> <p><b>NOTE (2):</b> W3 Re W25 Re (ASTM E 988-90)</p> <p><b>NOTE (3):</b> For two-wire connections, the end value is made up of the measured end value (Ω) plus the total resistance of the leads.</p>													

**Electrical Connections**

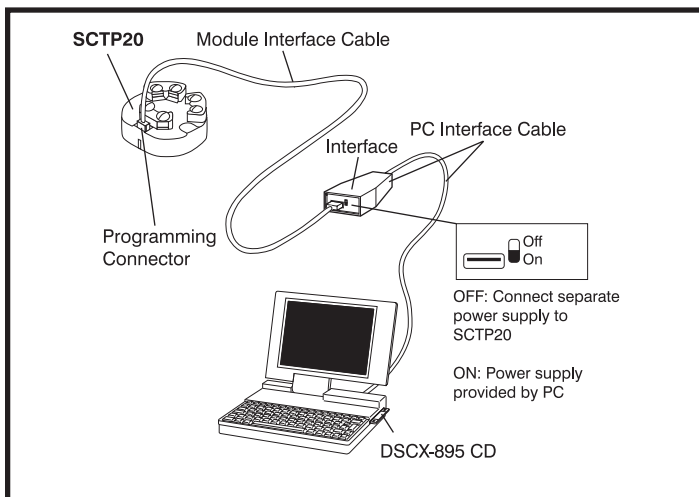
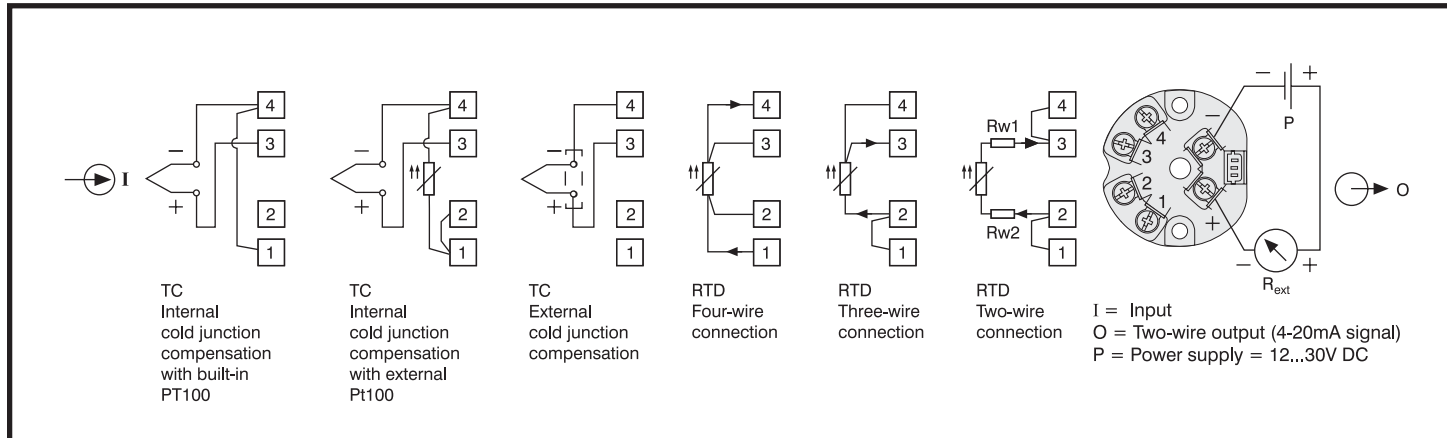

**Table 4: Accessories and Spare Parts**

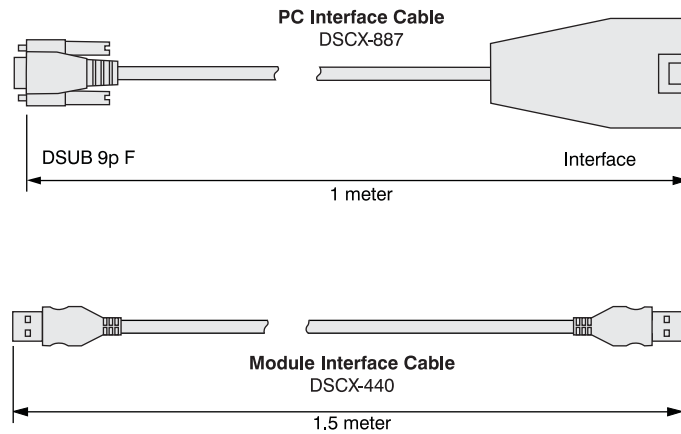

Example of the set-up for programming a SCTP20 without the power supply. For this case the switch on the interface must be set to "ON".

**Dimensions**

Dimensions: inches (millimeters)

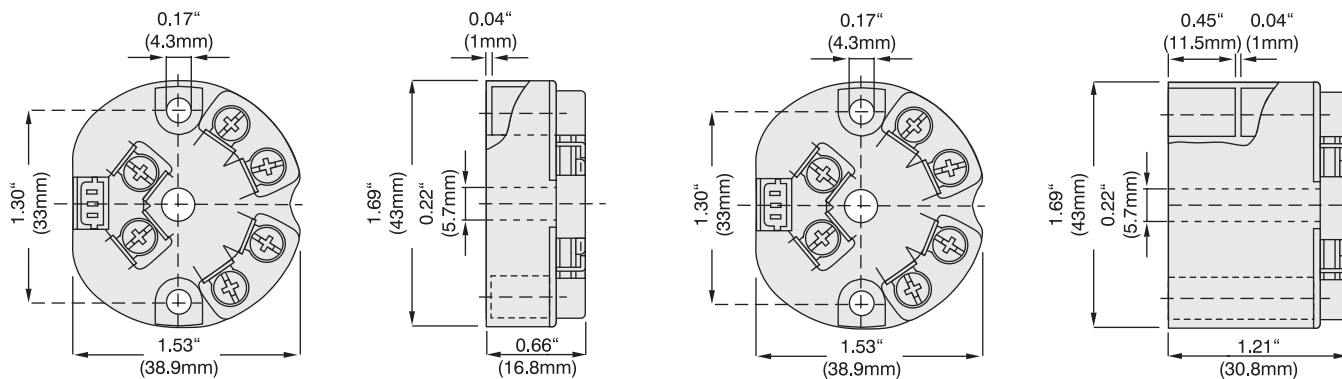

SCTP20-01 Input/Output **Not** Electrically Isolated

SCTP20-02 Input/Output Electrically Isolated